

DMD1.2 / DMD1.2C
Modulating Actuators

Application

The **JOVENTA SMALL** electric damper actuator series have been developed to operate small and medium air damper in ventilation and air conditioning systems. The compact design make this JOVENTA actuator highly versatile.

Features

- DC 0(2)...10 V or 0(4)...20 mA with field furnished 500 Ω resistor
- Load-independent running time
- Up to 5 actuators in parallel operation possible
- 1.2 M PVC Cable or Terminal block
- Simple direct-mounting with universal adapter for fitting to 8...13 mm Ø round axis or with 8...10 mm square shaft
- Selectable direction of rotation
- Manual release button
- Automatic shut-off at end position
- Devices meet CE requirements



Technical Specifications

Actuator	DMD1.2	DMD1.2C
Torque	4 Nm	
Damper area*	0.8 m ²	
Running Time	72 s (@ 50 Hz)	
Supply Voltage	AC 24 V +25% -20%	
Frequency	50-60 Hz	
Power Requirement	3.6 VA	
Control signal	DC 0(2)...10 V OR 0(4)...20 mA with field furnished 500 resistor	
Position signal	DC 0(2)... 10 V	---
Angle of rotation/working range	90° (93° mech)	
Cable	1.2 m PVC	Terminal block
Service Lifetime ca.	100.000	
Auxiliary Switches	None	
Noise Level	35 dB (A)	
Protection Class	II	
Degree of Protection	IP 42	IP 40
Ambient conditions		
- Operating temperature	-20...+60 °C / IEC 721-3-3	
- Storage temperature	-30...+65 °C / IEC 721-3-2	
- Humidity	5...95% r.F. no condensed	
Weight	0.5 Kg	
Service	Maintenance-free	
Standards		
- Mechanics	EN 60 529 / EN 60 730-2-14	
- Electronics	EN 60 730-2-14	
- EMC Emissions	EN 50 081-1:92 / IEC 61000-6-3:96	
- EMC Immunity	EN 50 082-2:95 / IEC 61000-6-2:99	

*Caution: Please note damper manufacturer's information concerning the open/close torque.

Ordering Codes

Codes	Descriptions
DMD1.2	4 Nm, AC 24 V with 1,2 PVC cable
DMD1.2C	4 Nm, AC 24 V with Terminal block

DMD1.2 / DMD1.2C
Modulating Actuators

Wiring Diagrams

DMD1.2

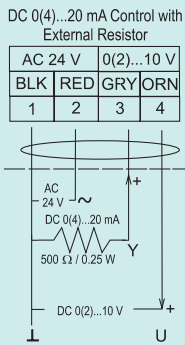
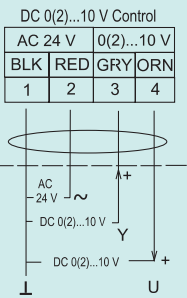

DMD1.2C

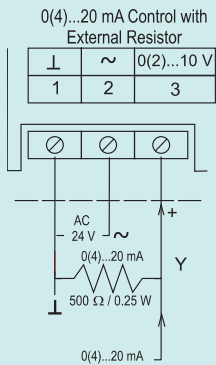
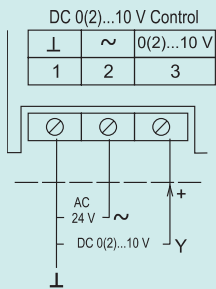

Dimensions in mm

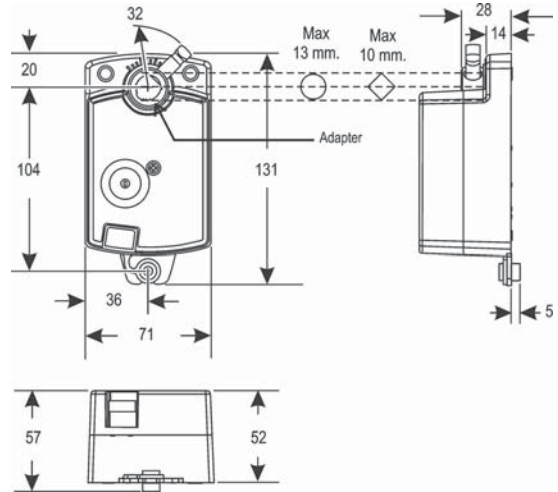

Inserting the Screw into the Shoulder Washer

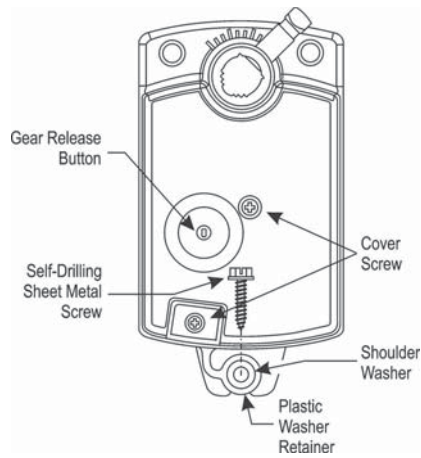

Mounting the Actuator onto the Damper Shaft

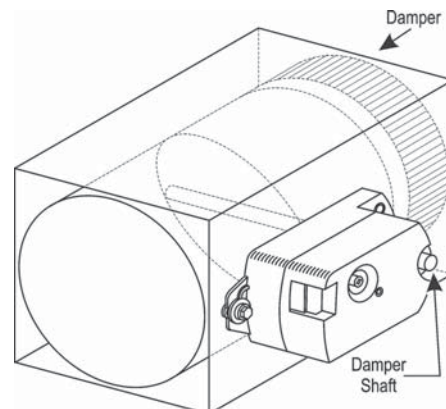

DMD1.2 / DMD1.2C
Modulating Actuators**Factory setting**

To change the factory setting, remove the actuator cover and adjust the switches on the circuit boards as figure.

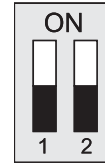
**Changing the Factory Settings**